

REDUCING TREATMENT PLANT OPERATIONAL COSTS THROUGH DYNAMIC SIMULATION MODELLING AND ONLINE INSTRUMENTATION

Dylan Kiernan - AWT

Richard Brice – AWT

ABSTRACT

This study investigates the application of a structured optimization process involving preliminary investigations, appropriate instrumentation, testing, and dynamic simulation software for the reduction of electricity usage and alum dosing at full scale nutrient removal plants.

This approach was used at Port Macquarie, a large town of 39,000 people (circa 2006) located on the Mid–North coast of New South Wales (NSW) roughly 390km north of Sydney and 570km south of Brisbane. The Port Macquarie WWTP optimization resulted in approximate cost reductions of 40% in electricity consumption and 80% in alum dosing and alum sludge disposal for their trial reactor.

KEYWORDS

EAT Basins, Nitrogen, Phosphorous, FRP, s::can, Dissolved Oxygen, ORP.

1 INTRODUCTION

It is common for plants to be operated based on operations manuals written during process design. The manuals often lead to the operation of plants based on inappropriate MLSS concentrations and preset DO concentrations, rather than on the present-day plant conditions and requirements. The process design, particularly for older plants, may have been based on guidelines or assumptions that are no longer valid or were based on limited data sets. Operationally plants, particularly plants with limited online instrumentation, may be operated to protect against worst-case effluent conditions, i.e. aerating constantly for occasional peak loads, or can focus too much on meeting consent conditions, i.e. on achieving ‘zero’ ammonia in the effluent, with little regard to doing so efficiently. In Biological Nutrient Removal (BNR) plants, operating to worst-case conditions and excessive focus on meeting consent conditions can lead to sub-optimal use of the influent stream’s resources (removing influent carbon rather than using it).

Accurate characterisation and development of simple functionality using on-line instrumentation is a proven mechanism for optimizing existing assets, which can defer large capital expenditure and allows for improvements in effluent quality and a reduction in consumable use. The reduction in consumables is particularly important as costs are often increasing and the associated greenhouse gas emissions are an ongoing concern, particularly in regard to power use. Often only minor changes or adjustments are required to achieve improvements.

There are a number of ways to review and optimise existing plant performance; one way is to use a structured approach such as the one outlined below:

1. Review overall plant in terms of treatment objectives and treatment fundamentals (i.e. plant setup).
2. Review the performance using appropriate instrumentation and testing, such as DO, ORP, flow, P-release, s::can, flow, and level data.

3. Use mass balances and dynamic model simulations to check current performance and any proposed changes.
4. Implement changes and track actual performance (this helps to improve future model performance and expand process knowledge).

This approach was used at Port Macquarie WWTP in Australia. This paper outlines the process followed that substantially reduced the final effluent Total Nitrogen and Phosphorous concentrations, as well as reducing power and other consumables. The improvements include the use of scan, Zullig DO and ORP probes and improved functionality to provide for Enhanced Biological Phosphorus Removal (EBPR) in a similar fashion to that described by Serralta et al (2004).

1.1 BACKGROUND

Port Macquarie is a large town located on the mid-North coast of New South Wales (NSW) approximately 390km north of Sydney and 570 km south of Brisbane. The population for Hastings Valley was 39,000 (circa 2006).

Port Macquarie-Hastings District owns and operates the Port Macquarie Wastewater Treatment Plant (WWTP). The Port Macquarie Wastewater Treatment Plant is configured as three parallel Intermittent Decant Extended Aeration basins (IDEAs; also know as Extended Aeration Tanks or EATs) and was originally designed to biologically remove both Nitrogen and Phosphorous. Table 1-1 presents the discharge license limits for the Port Macquarie WWTP. The key parameters are the Total Nitrogen and Phosphorous limits.

Table 1-1: Port Macquarie Discharge License Limits

Parameter	Limit 50%ile	95%ile	Maximum	Units
BOD ₅		10	20	mg/L
TSS	10	15	30	mg/L
Ammonia	2	5	15	mg/L
Total N	10	20		mg/L
Total P	0.7	1		mg/L
Oil and Grease		2	10	mg/L
Faecal Coliforms		200		cfu's/100mL

The Port Macquarie WWTP had been designed to biologically remove Nitrogen and Phosphorous to the levels presented above. Total Nitrogen levels have not traditionally been difficult to meet, however the process has always struggled to remove Phosphorous biologically. Alum had been dosed to the final effluent discharge point to ensure that the nutrient standards required by the NSW EPA were met. Long term usage of Alum had resulted in significant amounts of Alum sludge being deposited within the effluent lagoons. Due to this Port Macquarie-Hastings Council has had to remove the Alum sludge from the lagoons at significant cost.

The plant was reviewed with an aim to reduce power use and improving biological Phosphorus removal.

EAT1 was selected as the pilot plant to evaluate the potential power savings, and biological Phosphorous removal. Due to the sludge dewatering return streams it was recognized that the return Phosphorous

concentrations from EAT 2 and EAT 3 would increase the overall return load to the plant and could mask some of the pilot plant improvements.

Figure 1-1 below presents an overview of the Port Macquarie WWTP including the positions of the new instrumentation installed as part of this project.

Figure 1-1: Port Macquarie WWTP General Arrangement

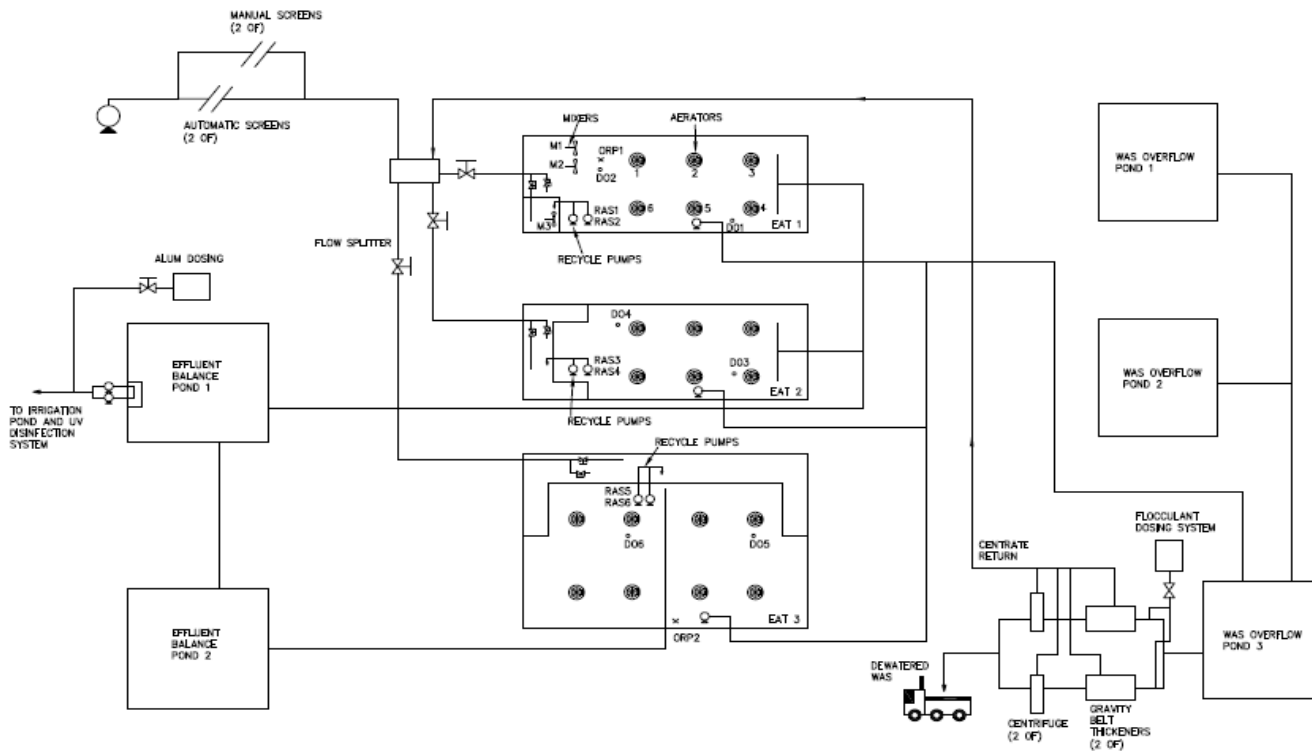

2 METHOD

2.1 REVIEW OF DRAWINGS AND FLOW CONFIGURATION

The plant drawings and flow configurations were reviewed and the treatment zones were identified. Figure 2-1 below presents the approximate zones that were identified.

Figure 2-1: Close up of EAT1 showing proposed zones

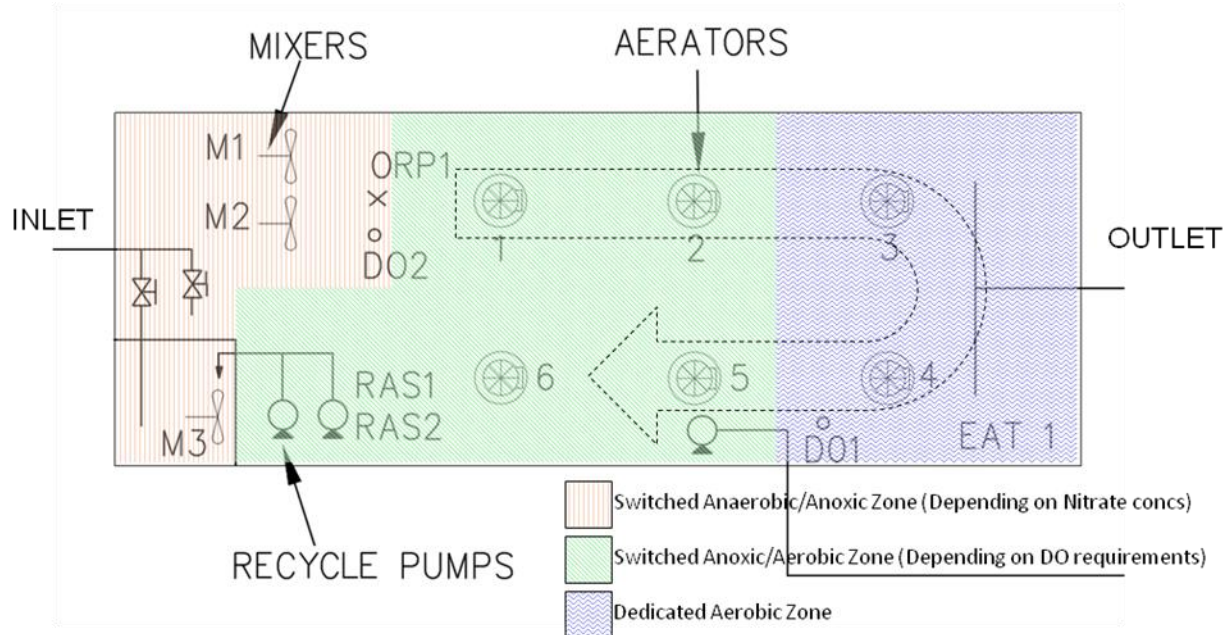

The switched zones change state depending on the aeration demand and on the concentration of nitrate in the recycle return.

The inlet configuration and the arrangement of the aerators and recycle pumps caused the EAT to act like a pseudo-oxidation ditch, as indicated by the flow arrow in Figure 2-1.

2.2 REVIEW OF EXISTING PERFORMANCE AND GATHERING OF DATA

Two Zullig Dissolved Oxygen (DO) probes (model S-14S) were installed within EAT 1 and a Zullig Oxidation Reduction Potential (ORP – pHBL - 25) probe installed alongside the DO probe. The locations of these are presented in Figure 2-1 above.

An online UV/Vis spectrophotometer was used to evaluate the diurnal patterns within the influent stream, particularly for COD (BOD₅ was the main plant parameter for operation prior to this investigation, and BOD₅ values were also reported). The on line instrumentation was set up to be evaluated in real time and provide detailed data which was extremely useful for not only the operation of the plant but also for design purposes. The plant operation was able to be controlled by the online and a combination of DO and ORP probe outputs.

EAT1's influent and level information was collected using existing instrumentation. Historical effluent data was provided by Port Macquarie-Hastings Council.

During the initial investigation AWT undertook actual Phosphorous release rate and uptake rate testing to ensure Phosphorous Organisms (PAOs) were present (similar to that method developed by Kang et al (1991). Tests were undertaken on site using the HACH spectrophotometer (DR2400 and methods 8114, 10031, 8000 and 10020). The batch tests were undertaken on site at Port Macquarie WWTP. These tests were completed as per the method presented with the STOWA manual by Jansen et al.

2.3 MASS BALANCE AND DYNAMIC MODEL SIMULATION

An online (on line UV spectrophotometer) was installed on the influent stream to measure influent COD concentrations in real time to evaluate the potential for Enhanced Biological Phosphorous Removal (EPBR). An initial process simulation model was constructed (using the BioWin process simulation modeling package as produced/developed by EnviroSim Associates Ltd) and a simple mass balance undertaken to review this potential. From this work it was discovered that there was distinct potential to greatly optimize the plant with very minor physical alterations particularly in terms of capital outlay. This hypothesis is as per Henze et al (2008) who suggest that effective control can increase the capacity of BNR plants by 10–30%

2.4 IMPLEMENTATION AND REVIEW

Six process modifications and enhancements were identified in the above process, these were:

- The existing mixer in the anoxic zone was removed;
- Two new mixers (7.4kW Flygt mixers) were installed in the main reactor basin;
- An ORP and a DO probe were installed at the “front end” of the aerobic/anoxic zone;
- The s::can was installed in the influent line to measure incoming loads for control and design purposes;
- New control functionality to utilise the above for EBPR was written; and,
- Reduced the base number of aerators operating under normal conditions from (from all six down to two).

The recommended changes were incorporated and the system underwent a period of onsite intensive testing to provide immediate feedback on the efficacy of the changes.

The EAT1 reactor’s DO, ORP, and level sensor data was telemetered to the internet to enable real-time remote data monitoring and logging. This data was available via a secure website so that AWT design staff (and Port Macquarie – Hastings Council staff) could review on line operation in real time and accurately and remotely assist operations staff. An example of the telemetered data is presented below in *Figure 2-2*.

Figure 2-2 Port Macquarie EAT1 telemetered DO, ORP, and level data

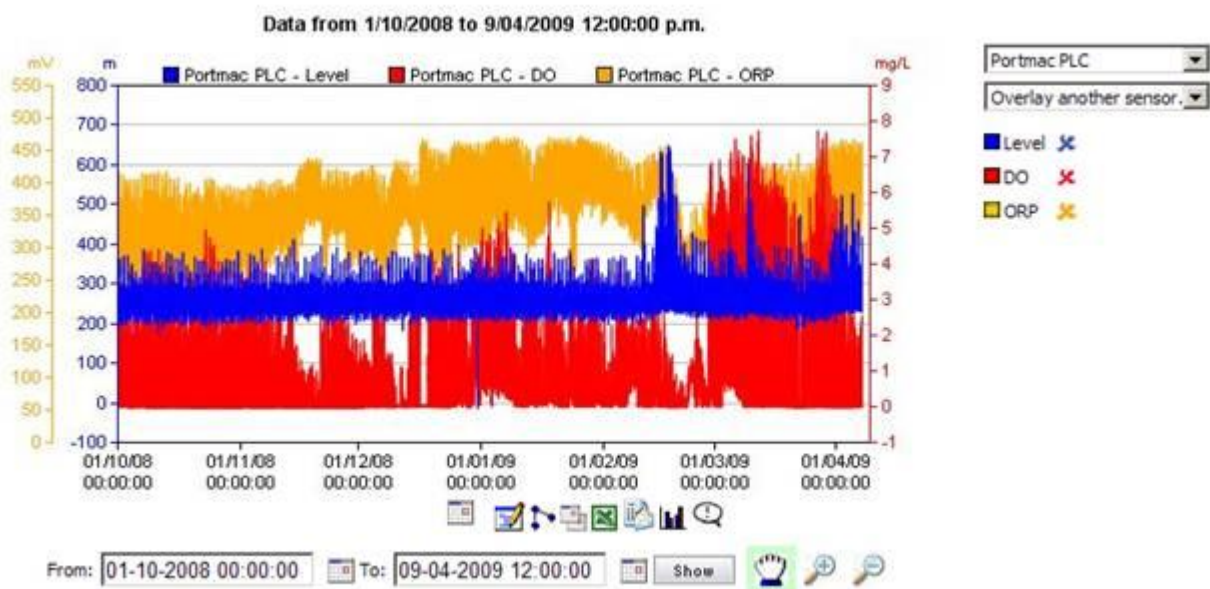

The system could also act as an independent alarm system. A decanter failure was identified during a remote review of the level sensor data; this failure could have been set up to trigger an automatic alarm using the telemetry system.

3 RESULTS

3.1 PRIOR TO CHANGES

The initial investigation highlighted that the reactor was receiving excessive aeration. This was evident from the following indicators:

- Aeration knee-point – the aeration knee-points (transition points between increased oxygen demand and reduced oxygen demand) were occurring early in the reaction cycle.
- Elevated ORP – the ORP readings indicated that aerobic and anoxic conditions predominated in the inlet zone (i.e. there was significant DO and nitrate carryover into the anaerobic zone).

- Installed Aerator Power – the mass balance and dynamic model indicated that normal conditions needed significantly less aerator power than was currently applied.
- Minimal Ammonia – effluent results showed no ammonia breakdown even during periods of higher load.

The data collected from the ORP probes demonstrated that ORP trends are more useful at indicating phase transitions than absolute ORP values. The ORP values of the aerobic, anoxic, and anaerobic phases sometimes changed cycle-to-cycle and day-to-day, but the overall ORP pattern did not. The phase transitions were evident as steps (knee-points) in the ORP trends; these were knee-points were particularly useful for indicating when the nitrate was exhausted and anaerobic conditions were dominating (promoting P-release and carbon stockpiling in Phosphate Accumulating Organisms (PAOs)).

Batch tests were undertaken and Phosphorous concentrations were recorded to ensure release mechanisms were functioning. These tests measured both the Nitrate and Ortho P concentrations to assess the effect of Nitrate on P release/uptake.

Figure 3-1 presents the results from one of the release tests undertaken comparing nitrate and phosphorous concentrations.

Figure 3-1: Phosphorous Release Rate Tests

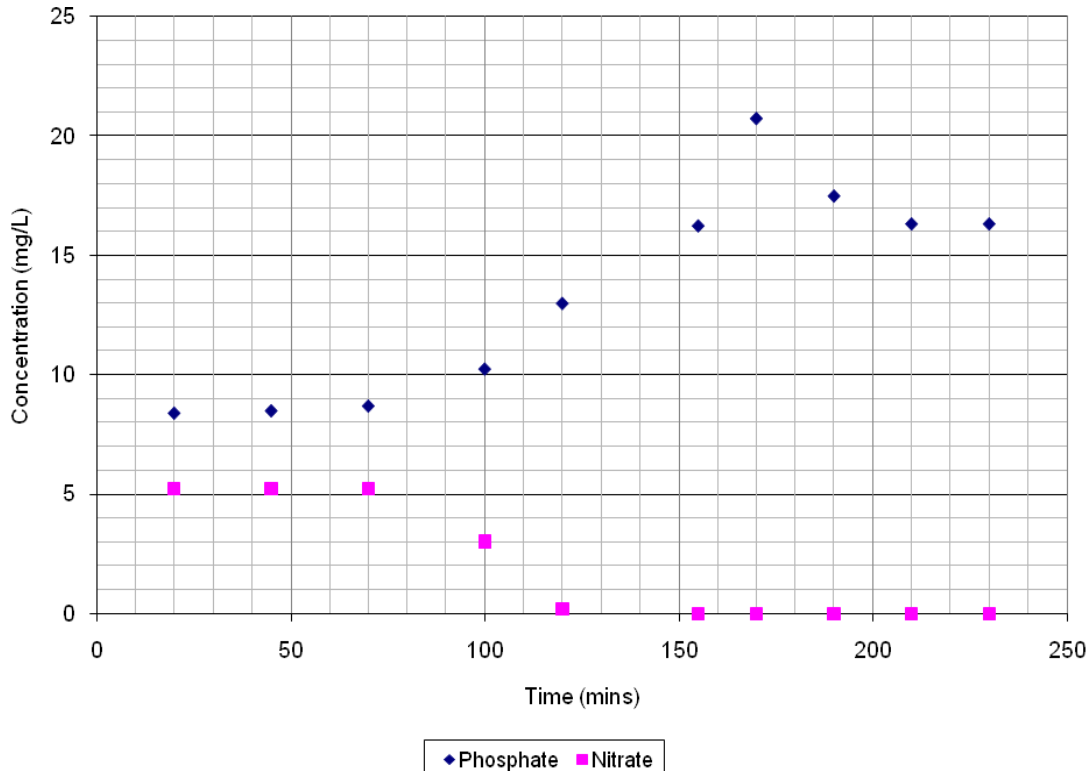

From both the release and uptake tests and the pilot plant trials it was quickly seen that reducing the effluent nitrate (and nitrite) concentration to a minimum allowed significantly increased Phosphorous release. As presented above rapid Phosphorous release occurs upon depletion of the nitrate concentrations within the reactor. It was however unclear as to what conditions occurred at the end of this test; with a drop in effluent P concentrations, with no alteration to the test conditions. It should be noted that Phosphorous release was witnessed in all tests.

The mass balances and dynamic simulations demonstrated that the Total Nitrogen (TN) and Total Phosphorus (TP) discharge license limits should be able to be met biologically without additional carbon or alkalinity.

3.2 AFTER THE CHANGES

After the alterations to EAT 1 the following was observed:

- Effluent Ammonia concentrations remained low.
- EAT1 Effluent Nitrate concentrations reduced from an average of approximately 13mg/L to an average of 2.5mg/L.

The EAT1 effluent Phosphorous concentrations reduced from an average of approximately 7mg/L to an average of approximately 4mg/L. Table 3-1 below presents the actual plant results before and after the alterations to EAT 1.

Table 3-1: Effluent Quality Pre and Post Alterations

Parameter	Pre Alterations		Post Alterations		Units
	Ave	95%ile	Ave	95%ile	
Aerator power	180kW		60kW		kW
NH ₃ -N	0.8	1.1	0.4	0.7	mg/L
NO ₃ -N	13.4	18.9	2.6	5.8	mg/L
TP	7.2	8.6	4.3	5.6	mg/L

Since the upgrade to EAT 1, with the inclusion of improved dissolved oxygen (DO) control, ORP measurement, influent measurement and the installation of two new mixers within the main reactor basin, the surface aerator operation has altered to the following (influent load dependant):

- Currently an initial 30 minute aeration phase (six surface aerators);
- 60 minutes on DO control generally requiring only two of the six surface aerators.

Prior to this alteration all six surface aerators operated for the entire 90 minute “react” phase. By adding 15kW of mixing power the plant was able to reduce the average reactor aeration power demand by 120kW (from six 30kW aerators to two 30kW aerators) for 60mins of the reaction phase, while simultaneously improving process performance.

Weekly sampled data is also presented in Figure 3-2 below. There is an area of no data for effluent nitrate as this data was not available for this period. Given the reactor conditions and the on line monitoring it is not expected that this data will be different to the data prior to or after the missing data set.

Figure 3-2: EAT 1 Effluent Data

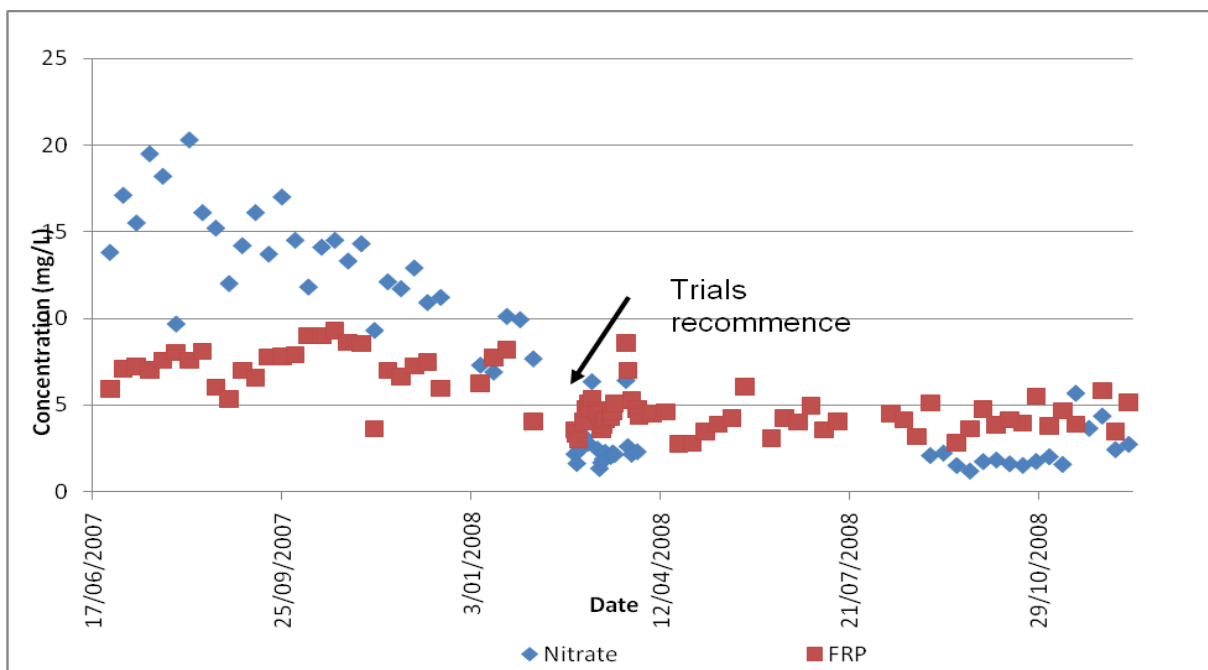

As presented above there was an immediate response to the alterations in the functionality and control of the plant both in terms of effluent Nitrate and Phosphorous concentrations.

A simple mass balance identified the return Phosphorous load to EAT 1 from the return streams to the plant. This equates to an extra (approximately) 1.5 – 2mg/L of Phosphorous (in terms of the effluent from EAT 1) which would otherwise not be present in the return streams.

Traditionally at Port Macquarie Alum dosing was used to reduce the effluent Phosphorus from 8mgP/L to 1.5mgP/L; a reduction of 6.5mgP/L. Once all of the reactors are modified the anticipated Alum-related phosphorus removal required could drop to 1.5mgP/L. The expected daily Alum usage could drop from approximately 1.3m³ per day to 0.3m³ per day, a decrease of 77% (assuming an average inflow of 14ML/d dosed with 50% strength Alum(14H₂O)). In New Zealand terms this would reduce the daily alum cost from NZ\$1300 per day to \$315 per day (2009 price; assuming IBC delivery in the Auckland area).

Post-change a drop was noted in the settle and decant ORP trend. This indicated the potential for phosphorus re-release prior to the decant. By superimposing the cycle over the ORP values it was apparent that the ORP values drop significantly during the decant phase with only sufficient Nitrate and dissolved oxygen to sustain or suppress the significant final drop in ORP values until towards the end of the settle phase. This was due to the end of the phase having low DO and nitrate concentration due to the reduction in aeration. The on-line ORP data from before and after the optimization as presented in Figure 3-3 below.

Figure 3-3: A comparison of pre and post change normalized ORP trends

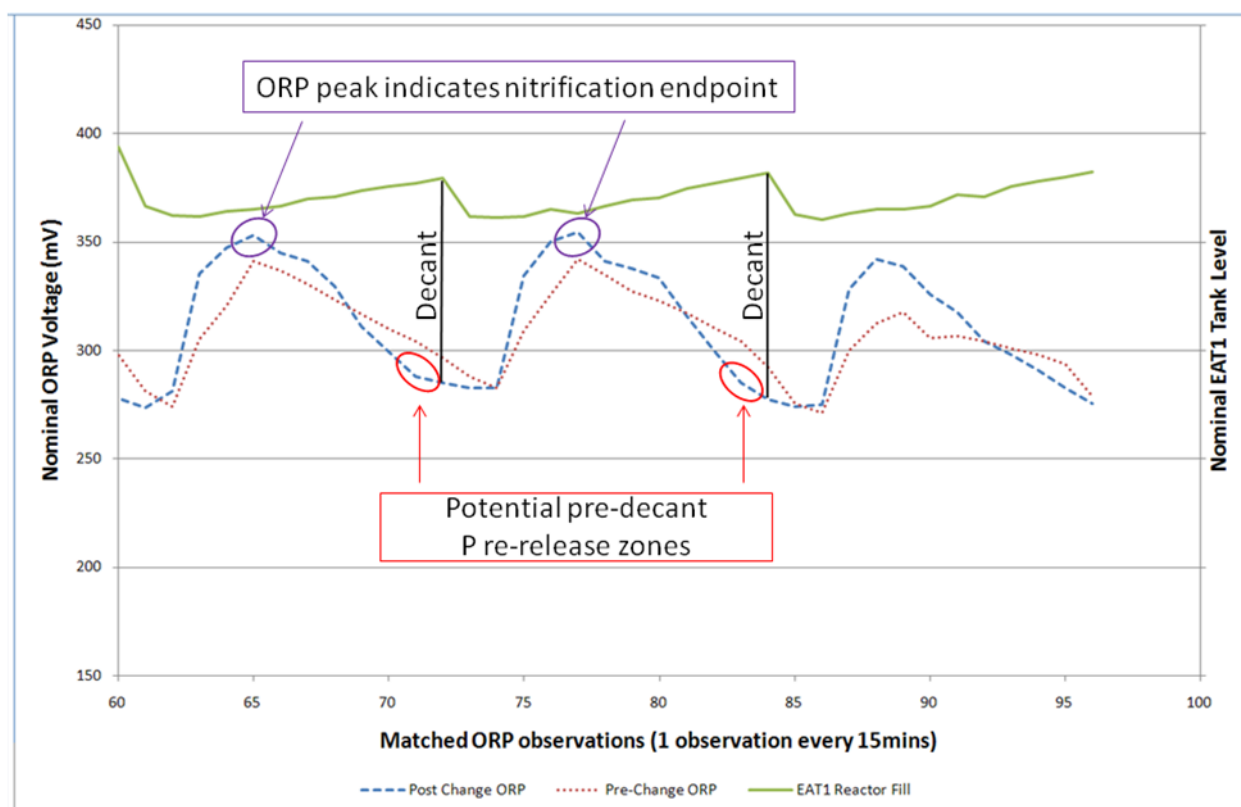

These pre-decant knee-points indicate potential Phosphorus re-release which can elevate the effluent Phosphorus concentrations. The intention is to move wasting (and its associated aeration) to the end of the reaction phase, so the water's ORP is elevated prior to settled and decant.

4 DISCUSSION

4.1 EBPR THEORY

The EAT basins are essentially a Sequencing Batch Reactor (SBR) which operate on a fill and draw activated sludge mechanism. In fact the USEPA (1999) discuss this in their Wastewater Fact Sheet for SBRs calling the

Intermittent Cycle Extended Aeration System a “modified version” of the SBR with the key difference being continuous inflow. Whilst traditionally being constructed for Nitrogen removal there is also potential for EBPR. Once the nitrate – nitrogen is utilised by micro organisms, Sulphate becomes the next electron acceptor and anaerobic conditions prevail (USEPA, 1999). This is more traditional EBPR thought for Phosphate Accumulating Organisms (PAOs) (where a wastewater treatment biomass removes Phosphorous beyond its anabolic requirements by accumulating intracellular polyphosphates (polyP) reserves); with static fill conditions favouring storage mechanisms during start up (USEPA, 1999). This reaction that was first documented in the late 1950s, following the pathway as follows (WEF, 2008):

Release mechanism:

- $\text{PAOs} + \text{stored Poly P} + \text{Mg}^{+2} + \text{K}^+ + \text{glycogen} + \text{VFA} \rightarrow \text{PAOs} + \text{stored biopolymers} + \text{Mg}^{+2} + \text{K}^+ + \text{CO}_2 + \text{H}_2\text{O} + \text{PO}_4^{-3}$

Storage mechanism:

- $\text{PAOs} + \text{stored biopolymers} + \text{Mg}^{+2} + \text{K}^+ + \text{O}_2 \text{ (or NO}_3\text{)} + \text{PO}_4^{-3} \rightarrow \text{PAOs} + \text{stored Poly P} + \text{Mg}^{+2} + \text{K}^+ + \text{CO}_2 + \text{H}_2\text{O} + \text{glycogen}$

Some Phosphorous is also up taken as part of the normal growth cycle during wastewater treatment and this contributes to approximately 1.5–2% on a dry weight basis (WEF & ASCE, 2004).

The internal recycle to the “Anaerobic Zone” of the reactor is from the front end of the main react zone of the basins. This zone is deemed to be fully mixed, and as such if the return nitrate concentration is as per the final effluent as described by McGrath et al (2005) who state that 6mg/L is the upper limit for step feed type systems for successful EBPR (for in particular one full scale operation). This hypothesis was also supported by the site testing undertaken. Clearly then the potential for EBPR (and hence uptake) is limited by the Nitrite and Nitrate concentration within the basin. Previously DO concentrations were also being returned due to the effect of the aerator closest to the recycle pump. Further optimisation may lead to this aerator being permanently switched off. As such the focus of the modifications was to reduce the return DO and the effluent Nitrite and Nitrate concentration as much as possible to allow for EBPR. The post-modification effluent results suggest that the mechanisms above were applicable in this situation.

Further to this Dassanayake and Irvine (2008) discuss over aeration as providing a risk for uptake of Phosphorous within the aeration phase. As such there is a further benefit of reducing the aeration time to that described for Nitrate/Nitrite removal above.

EBPR is broadly dependent on the following parameters:

- Readily degradable organic carbon and phosphorous in the influent.
- Sufficient anaerobic zone volume (from hydraulic and solids retention time basis).
- Sufficient cations (e.g. Magnesium and Potassium) to facilitate the release and uptake of Phosphorous.
- Reduction (where possible) of non – PAOs in the anaerobic zone.

The degradable organic carbon is essential for Phosphorous release in the anaerobic zone. Research from Baetens¹ states that it is usually assumed that this degradable carbon needs to be in the form of volatile fatty acids (VFAs) mainly in the form of acetate, propionate or butyrate, or in a form that can be easily hydrolysed or fermented to VFA within the process.

In the process biomass passes through an oxygen and nitrate free zone, an anaerobic zone, prior to entering an anoxic and/or aerobic zone where oxygen as an electron acceptor is present.

When the wastewater enters the anaerobic zone poly-phosphate accumulating bacteria (PAOs) accumulate carbon sources (degradable carbon is readily accumulated) as an internal polymer within the cell, most commonly as polyhydroxybutyrate (PHB). The energy used in this reaction is obtained from breakdown and

hydrolysis reactions of the poly – Phosphate (poly – P). The poly – P is broken down to orthophosphate in the anaerobic zone and as such the total P concentration in the anaerobic zone increases.

When the PAOs move into an anoxic or aerobic zone, the polymer (most commonly PHB) is consumed, generating energy for growth and the orthophosphate is taken from the liquid. This is then bound within the cell and removed via the sludge wasting process (it must be noted that the wasted sludge must be retained in an aerobic form or the secondary P release process will occur and orthophosphate will be returned within the return liquors). Under these conditions the orthophosphate concentration decreases.

In this uptake process the biomass is then capable of storing up to 4-12% of their dry weight. This is a net gain in Phosphorous stored within the biomass cell, up from typical values of approximately 1.5-2%. As such wastage of solids results in approximately 2.5 to 4 times more Phosphorous being removed from the system than in conventional systems.

Initially it was thought that this just occurred in the aerobic zone; however there are mechanisms for anoxic P – removal which can have some advantages over simple anaerobic/aerobic system; with relation to sludge production, oxygen requirements and sludge settleability.

4.2 PHOSPHORUS RELEASE TESTING

Traditionally the discharge nitrate quality at Port Macquarie WWTP was in the order of 6 – 8mgNO_x/L. This had been apparent through all of the basins within the treatment plant. Basic theory of oxygen uptake will present the hypothesis that oxygen from Nitrogen will be utilised prior to the oxygen (and energy transfer) from Phosphorous. This in some way explains the situation exhibited within the onsite Phosphorous release tests with Anoxic Phosphorous release being witnessed. Further testing and research is desirable however the scope of the study did not allow time to undertake further testing to further explain some of the anomalies witnessed during the release testing.

A comparison of the measured phosphorus release rates for Port Macquarie and Auckland’s Mangere WWTP (370ML/d) is tabulated below:

Table 4-1: Comparison of Port Macquarie WWTP and Mangere WWTP Phosphorus release rates

Carbon Source	Port Macquarie Release Rate mgP/gVSS.h	Mangere WWTP Release Rate mgP/gVSS.h
Acetate	5.6	18
Wastewater		2.0
Without carbon (endogenous)		1.8

It is believed that prior to this study the conditions in Port Macquarie’s WWTP, unlike at Mangere, have not been suitable for growing Phosphorus Accumulating Organisms (PAOs). The small population of Port Macquarie PAOs resulted in a reduced phosphorus release rate.

Janssen et al (2002) characterize Phosphorus release rates as:

Moderate (< 3mgP/gVSS.h);

Good (3 - 7mgP/gVSS.h); and,

Very Good (>7mgP/gVSS.h).

4.3 PHOSPHORUS RE-RELEASE POTENTIAL

An initial 30min six-aerator aeration period was required to enable the tank to be fully mixed during sludge wasting. It was intended that this would be altered to allow all surface aerators to operate at the end of the aeration period rather than at the start, however the age of the Motor Control Centre (MCC) meant that this could not be completed prior to this study.

Common theory for biological Phosphorous removal suggests that secondary release may occur if the process once again becomes anaerobic (i.e. during settle and decant). The ORP data indicated the transition to anaerobic conditions, however further testing would be required to quantify the amount of Phosphorus re-release occurring

4.4 PLANT EFFICIENCY AND EFFLUENT QUALITY IMPROVEMENT

Port Macquarie - Hastings District Council has realized a distinct improvement in effluent quality combined with a significant reduction in power usage. Port Macquarie - Hastings District Council are intending to alter the remaining two basins EAT 2 and EAT 3 to operate with the new functionality.

The phosphorus in the recycled streams from the other extended aeration tanks (EAT2 and EAT3) was likely to be increasing the phosphorus load to EAT1. Once the extra load is removed, following the expected upgrade of EAT2 and EAT3, it is expected that the EAT1 effluent phosphorus will drop by a further 1-2mgP/L.

The improvements in efficiency and effluent were the result of improved plant carbon management. Removing carbon aerobically, via heterotrophic biomass, is energy intensive due to aeration power demands. Aerobic carbon removal also uses oxygen that is needed for nitrifying organisms to oxidize ammonia, and indiscriminately consumes the substrates required for denitrification and EBPR.

Denitrification and EBPR consume carbon using only mixing energy and have the added benefit of reducing other pollutants (N and P respectively). It is recommended that the following carbon hierarchy is followed to maximize the efficiency of carbon use and removal:

1. EBPR (uses the Volatile Fatty Acid (VFA) component of the reactor's COD);
2. Denitrification (uses the Volatile Fatty Acid (VFA) component of the reactor's COD); and then,
3. Heterotrophic (aerobic) polishing of the remaining COD.

Improved carbon management helped to promote biological phosphorus removal. The improved biological phosphorus removal led to reductions in plant Alum use (and should lead to greater reductions once EAT2 and EAT3 are optimized). The Alum reductions had two main benefits for the Port Macquarie WWTP:

1. Reduced chemical costs; and,
2. Reduced final effluent pond desludging requirements (and related costs).

At many plants a third potential benefit of reducing alum dosing is improved reactor alkalinity. Each kg of Alum ($14\text{H}_2\text{O}$) added to a plant's wastewater consumes approximately 0.5kg of CaCO_3eq and may result in the requirement for external alkalinity addition (at additional cost). This was not the case at Port Macquarie as the Alum was added downstream of the plant recycle streams.

By maximizing their carbon use in the above investigations and carrying out associated process enhancements it was estimated that Port Macquarie - Hastings Council would be able to realize approximately AU\$110,000 per annum in power cost savings and reduced Alum related costs once all reactors have had functional alterations completed (approximate cost reductions of 40% in electricity consumption and 80% in alum dosing and alum sludge disposal).

Further to this, significant reduction in effluent Nitrate and hence Total Nitrogen concentrations as well as effluent Total Phosphorous concentrations have been realized.

5 CONCLUSIONS

At Port Macquarie the combination of site investigations, process mass balances and accurate altered functionality improved effluent quality, both in terms of Nitrogen and Phosphorous and had the added benefit of reducing power and consumables.

The optimization involved minimal capital expenditure and focused on improving the plant's carbon management.

Further improvements are being undertaken and due to instrumentation being on line real time remote assessment and assistance can be provided.

It is envisaged that the EAT1 effluent Phosphorus concentrations will improve further once the other reactors (EAT2 and EAT3) have been optimized (reducing the phosphorus load in the recycle streams).

It is common for plants to be operated based on initial operations manuals written during process design. This design; particularly for older plants can also be undertaken on a BOD basis or a COD basis with significant safety factors due to the level of detail available for influent parameters during design. These manuals often lead to operation of plants based on MLSS concentrations and pre set DO concentrations. Accurate characterisation and development of simple functionality using on line instrumentation is a proven mechanism of optimizing existing assets which defers large capital expenditure and allows for improvements for effluent quality and reduction in consumables. This is important as consumable costs are often increasing and with particular regard to power; greenhouse gas emissions are of increased concern.

6 ACKNOWLEDGEMENTS

We would like to acknowledge the assistance of Port Macquarie-Hastings Council staff in performing this study.

7 REFERENCES

- Baetens, D. (2000) *Enhanced Biological Phosphorous Removal: Modelling and Experimental Design*, Universiteit Gent.
- Dassanayake, C. and Irvine, R. (2001), *An enhanced biological phosphorous removal (EBPR) control strategy for sequencing batch reactors (SBRs)*, Water Science and Technology, IWA Publishing.
- Henze, M. van Loodrecht, M.C.M. Ekama, G. and Brdjanovic, D. (2008) *Biological Wastewater Treatment – Principles, Modelling and Design*, IWA Publishing, Cambridge University Press.
- Janssen, P.M.J. Meinema, K. and van der Roest, H.F. (2002) *Biological Phosphorous Removal: Manual for Design and Operation*, Water and Wastewater Practitioner Series, STOWA Report.
- Kang, S. J., T. J. Astfalk, C. J. Englert, and R. R. Deline. (1991) 'A new procedure for screening feasibility of biological phosphorus removal for a wastewater' *Water Science and Technology* 23:595-602.
- McGrath, M., G. Shero, and J. Welton. (2005) Fermentation for Improving Nutrient Removal at a Virginia Wastewater Treatment Facility. In Proceedings of the Water Environment Federation's 78th Annual Technical and Educational Conference, Washington, DC, October 29–November 2, 2005.
- Serralta et al, (2004) 'Monitoring pH and electrical conductivity in an EBPR sequencing batch reactor', *Water Science and Technology*, Vol 50, IWA Publishing.
- USEPA, (1999) *Wastewater Technology Fact Sheet: Sequencing Batch Reactors*, Office of Water, Washington D.C.

WEF, (2008) *Municipal Nutrient Removal Technologies Reference Document, Volume 1 – Technical Report*, WEF.

WEF (Water Environment Federation), 2004, and ASCE (American Society of Chemical Engineers) 1998, *Design of Municipal Wastewater Treatment Plants, WEF Manual of Practice 28*, WEF Press, Alexandria, VA, USA.
